

Dimensions (mm)

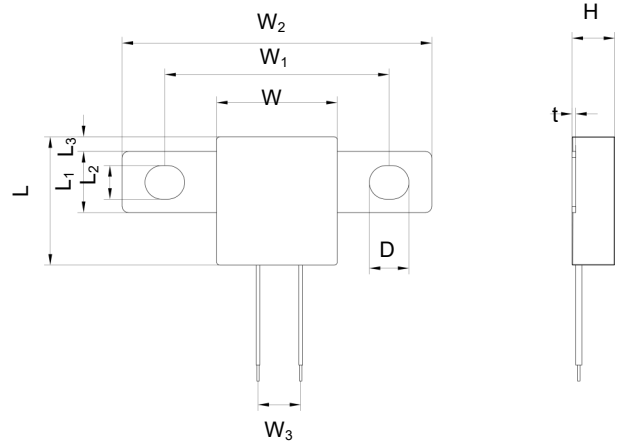

L	L ₁	L ₂	L ₃	W	W ₁	W ₂	W ₃	H	t	D
21.0 ± 0.5	10.0 ± 0.5	5.5 ± 0.2	2.4 ± 0.5	19.8 ± 0.5	36.8 ± 1.0	50.8 ± 1.0	7.0 ± 1.0	7.0 ± 1.0	0.6 ± 0.1	6.5 ± 0.5

Description

JDxxx-R series construction consists of thermal element with low melting point, flux resin and electrode leads. The control part consists of Feed Heater (FH) and ATCO, which is used to cut off control circuit.

Features

- Low Impedance, Low Power Consumption
- Fast Response Clearing Time ≤ 20 seconds
- Non-Resettable
- Active Control
- Over Temperature Protection
- Self-Control Protection
- RoHS & REACH Compliant

Application

- Battery Control Unit Fail Protection
- High Power Solid State Relays

Structure Diagrams

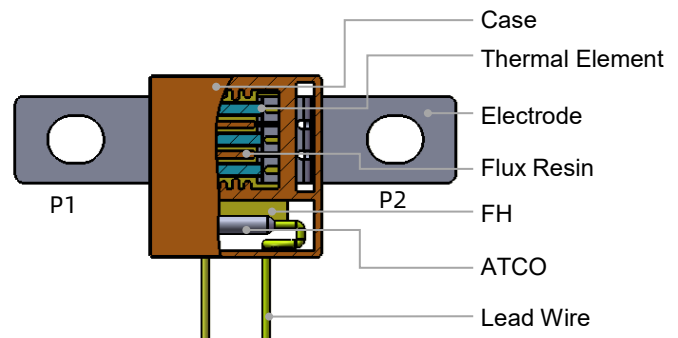

Product Schematic

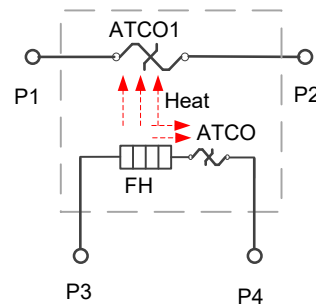

- P1 - P2 Main Circuit (MC)
- P3 - P4 Control Circuit (CC)

Glossary

Item	Description
iTCO	idea Thermal-Link After receiving control signals to fuse the protector.
TCO	Thermal-Link A non-resettable device incorporating a THERMAL ELEMENT which will open a circuit once only when exposed for a sufficient length of time to a temp. in excess of that for which it has been designed.
ATCO	Alloy Thermal-Link Alloy type Thermal-Link, Alloy is thermal element.
FH	Feed Heater Electric appliances that use electric energy to achieve heating effect.
MC	Main Circuit All conductive components used in switching devices for closing or disconnecting circuits in a circuit.
CC	Control Circuit In addition to the main circuit, all conductive parts of the switching apparatus used in the access circuit as the closing operation and / or opening operation of the switching apparatus.
I_r	Rated Current The current used to classify an iTCO, which is the Maximum current that iTCO allows to carry and is able to cut off the circuit safely.
U_r	Rated Voltage The voltage used to classify an iTCO, which is the Maximum voltage that iTCO allows to carry and is able to cut off the circuit safely.
T_f	Rated Functioning Temp. The temperature of the Thermal-Link which causes it to change the state of conductivity with a detection current up to 10 mA as the only load. Tolerance: $T_f 0 / -10$ °C (GB 9816, EN 60691, K60691). Tolerance: $T_f \pm 7$ °C (J60691).
Fusing Temp.	Fusing Temp. The temp. of the iTCO which causes it to change its state of conductivity is measured with silicone oil bath in which the temp. is increased at the rate of (0.5 to 1) °C /minutes, with a detection current less than 10 mA as the only load.
T_h	Holding Temp. The Maximum temp. at which a iTCO will not change its state of conductivity when conducting rated current for 168 h.
T_m	Maximum Temp. Limit The temp. of the iTCO stated by the manufacturer, up to which the mechanical and electrical properties of the iTCO having changed its state of conductivity, will not be impaired for a given time.

Specifications

Model	Main Circuit Specifications						Control Circuit Specifications		Fusing Time	
	T_f	Fusing Temp.	T_h	T_m	I_r	U_r	U_c	Cold Resistance	t1 (P1 ~ P2)	t2 (P3 ~ P4)
	(°C)	(°C)	(°C)	(°C)	(A)	(V)	(VDC)	(Ω)	(s)	(s)
JD102-R2N-MKZ	102	99 ± 2	60	180	40	AC 250 DC 150	24	8.0 ± 7.5%	≤ 20	t1 + (0 to 20)
JD115-R2N-MKZ	115	112 ± 2	74	180	40	AC 250 DC 150	24	8.0 ± 7.5%	≤ 20	t1 + (0 to 20)
JD125-R2N-MKZ	125	122 ± 2	85	180	40	AC 250 DC 150	24	8.0 ± 7.5%	≤ 20	t1 + (0 to 20)
JD136-R2N-MKZ	136	132 ± 2	94	180	40	AC 250 DC 150	24	8.0 ± 7.5%	≤ 20	t1 + (0 to 20)
JD150-R2N-MKZ	150	146 ± 2	115	180	40	AC 250 DC 150	24	8.0 ± 7.5%	≤ 20	t1 + (0 to 20)
JD102-R5N-MKZ	102	99 ± 2	60	180	40	AC 250 DC 150	48	22.0 ± 7.5%	≤ 20	t1 + (0 to 20)
JD115-R5N-MKZ	115	112 ± 2	74	180	40	AC 250 DC 150	48	22.0 ± 7.5%	≤ 20	t1 + (0 to 20)
JD125-R5N-MKZ	125	122 ± 2	85	180	40	AC 250 DC 150	48	22.0 ± 7.5%	≤ 20	t1 + (0 to 20)
JD136-R5N-MKZ	136	132 ± 2	94	180	40	AC 250 DC 150	48	22.0 ± 7.5%	≤ 20	t1 + (0 to 20)
JD150-R5N-MKZ	150	146 ± 2	115	180	40	AC 250 DC 150	48	22.0 ± 7.5%	≤ 20	t1 + (0 to 20)
JD102-R7N-MKZ	102	99 ± 2	60	180	40	AC 250 DC 150	72	50.0 ± 7.5%	≤ 20	t1 + (0 to 20)
JD115-R7N-MKZ	115	112 ± 2	74	180	40	AC 250 DC 150	72	50.0 ± 7.5%	≤ 20	t1 + (0 to 20)
JD125-R7N-MKZ	125	122 ± 2	85	180	40	AC 250 DC 150	72	50.0 ± 7.5%	≤ 20	t1 + (0 to 20)
JD136-R7N-MKZ	136	132 ± 2	94	180	40	AC 250 DC 150	72	50.0 ± 7.5%	≤ 20	t1 + (0 to 20)
JD150-R7N-MKZ	150	146 ± 2	115	180	40	AC 250 DC 150	72	50.0 ± 7.5%	≤ 20	t1 + (0 to 20)

Part Numbering System

iTCO - JD125 - R 2 N - M K Z

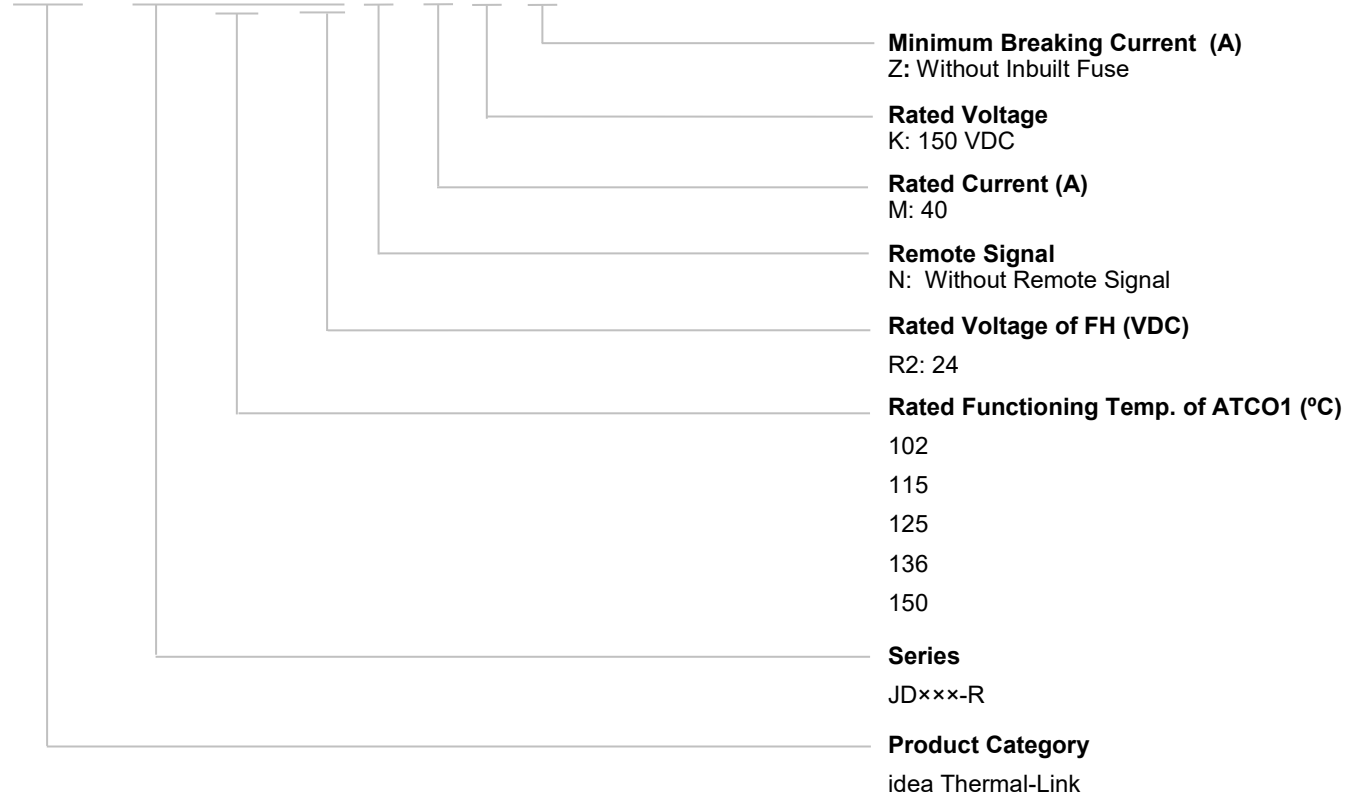

Agency Approvals for ATCO2

	Rated Functioning Temp. (T _f)	Agency Approvals					
							
ATCO2		UL	CUL	TUVEN 60691	PSE	CCC	KC
Model		UL 60691	CAN-CSA-E60691	EN 60691	J60691	GB 9816	K60691
	(°C)	E214712	E214712	R50112716	PSE15020870 PSE15020871 PSE15020872 PSE15020873 PSE15020874	2009010205350868	SU05023-11001 SU05023-11002 SU05023-11003
V6	145	•	•	•	•	•	•
V7	150	•	•	•	•	•	•

Marking

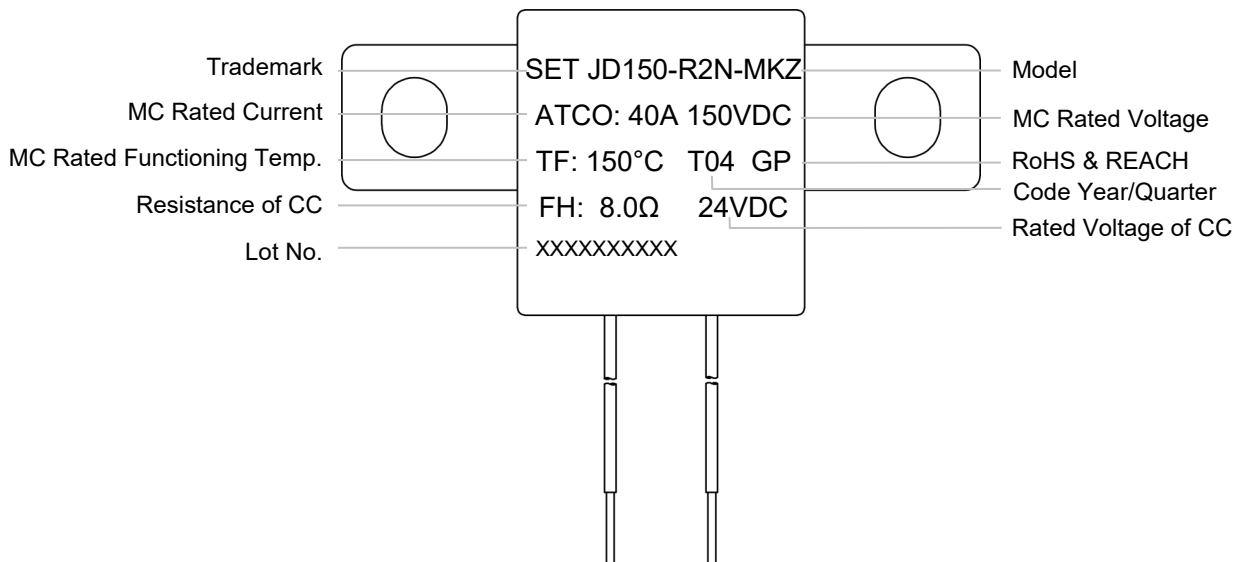

Product Current-Time Curve (Reference)

The Current-Time Curve shows functioning time at multi-times rated current at room temperature $25 \pm 2 \text{ }^\circ\text{C}$.

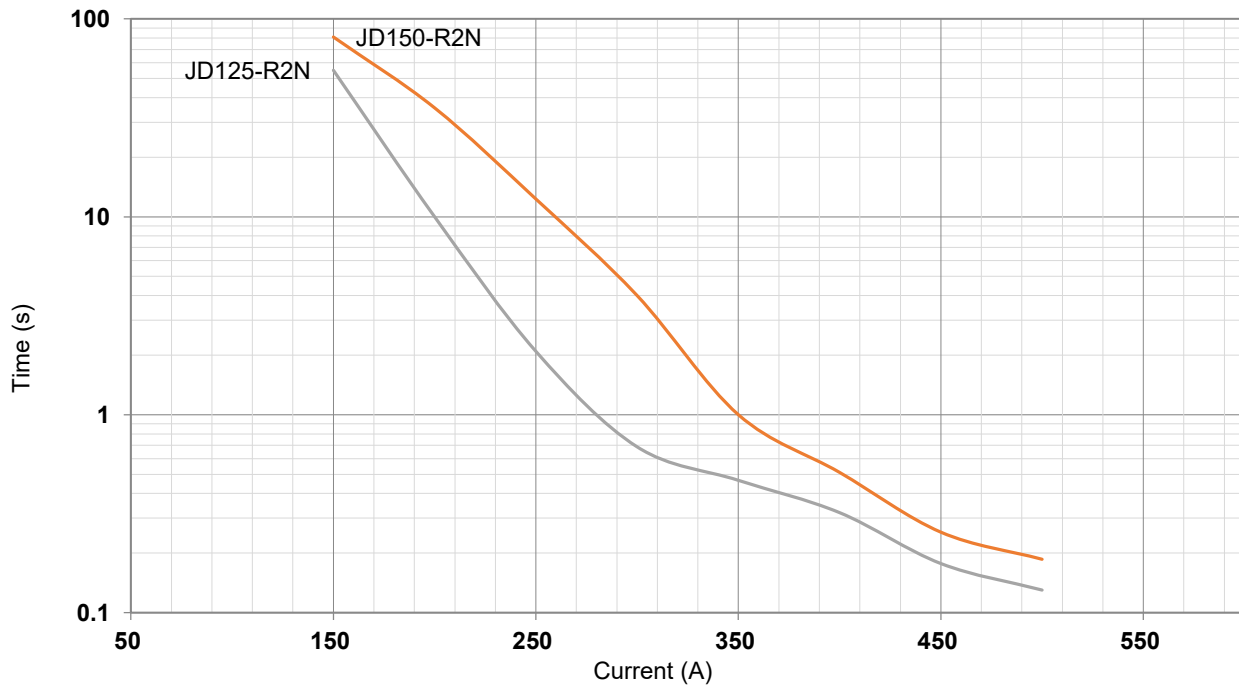



ATTENTION

Usage

1. When atmosphere pressure is from 80 kPa to 106 kPa, the related altitude shall be from 2000 meter to - 500 meter.
2. Operating voltage less than rated voltage of iTCO, operating current less than rated current of iTCO.
3. Do not touch the iTCO body or leads directly when power is on, to avoid burn or electric shock.

Electrical Connections

Mechanical Connection MC

1. The product surface must not be damaged.
2. If adding terminals to electrode leads, make sure the electrode without grease or other foreign matters, and use the same cross-section connection terminal, otherwise the electrode may heat abnormally.
3. If locking with screw, to prevent loosening, please add gasket and use proper screw when installing the product. Ensure that the screw tightening torque meets the requirements.

Soldering CC

1. Soldering should be carried out under the soldering conditions listed in table JDxxx-R-1.
2. Feed heater and remote signal CC contain thermal element, improper soldering operation (too high soldering temperature, too long soldering time, too short lead wire etc.) may cause CC to open in advance.
3. When soldering conditions are more severe than those listed in table JDxxx-R-1, a heat sink fixture should be used between solder point and iTCO body.

TABLE JDxxx-R-1 Hand - Soldering Time (s)

Rated Functioning Temp. T_f	The Max. Allowable Soldering Time for Different Lead Length (s)						Max. Soldering Temp.
	Lead Length	Max. Allowable Soldering Time	Lead Length	Max. Allowable Soldering Time	Lead Length	Max. Allowable Soldering Time	
(°C)	(mm)	(s)	(mm)	(s)	(mm)	(s)	(°C)
102 ~ 115	10	5	20	6	30	7	400
116 ~ 135	10	6	20	8	30	9	
136 ~ 150	10	8	20	9	30	9	

Test Methods

Cold Resistance Test

- If product TCR is not less than 350 E (-6) / °C and the test ambient Temperature is during 15 °C to 35 °C, the measured resistance value shall be corrected as the relative resistance value under 25 °C according to TCR formula.
- Resistance Measurement (4-wire).

Replacement

iTCO is the non-resettable product, for safety sake, please use the same type of iTCO for replacement.

Storage

Please store the iTCO without high Temperature, high humidity or corrosive gas. To avoid influencing the solder-ability of the leads and influencing contact resistance, please use them up within 1 year after receiving the goods.

Packaging Information

Item	Pearl cotton tray	Carton
Dimensions (mm)	300 × 210 × 12	314 × 224 × 120
Quantity (PCS)	20	400
Gross Weight (kg)		3.7 ± 10%

